

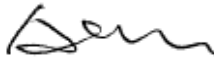





















<b>TEST REPORT</b> <b>EN 50530</b> <b>Overall efficiency of grid connected photovoltaic inverters</b>	
<b>Report:</b>	
Report Number .....	6041106.50
Date of issue.....	2018-11-01
Total number of pages .....	29 pages
<b>Testing Laboratory</b> .....	
DEKRA Testing and Certification (Shanghai) Ltd.	
Address .....	3F, #250 Jiangchangsan Road, Building 16, Headquarter Economy Park Shibe Hi-Tech Park, Zhabei District, Shanghai 200436, China
<b>Applicant's name</b> .....	
Shenzhen SOFAR SOLAR Co., Ltd.	
Address .....	5/F, Building 4, Antongda Industrial Park, No.1 Liuxian Avenue, Xin'an Street, Bao'an District, Shenzhen, P.R. China
<b>Test specification:</b>	
Standard.....	EN 50530:2010+A1:2013
Test procedure.....	Type test
Non-standard test method.....	N/A
<b>Test Report Form No.</b> .....	
EN50530_V1.0	
Test Report Form(s) Originator .....	DEKRA Testing and Certification (Shanghai) Ltd.
Master TRF.....	Dated 2014-05
<b>Test item description</b> .....	
Grid-connected PV Inverter	
Trade Mark .....	
Manufacturer .....	Shenzhen SOFAR SOLAR Co., Ltd. 5/F, Building 4, Antongda Industrial Park, No.1 Liuxian Avenue, Xin'an Street, Bao'an District, Shenzhen, P.R. China
Model/Type reference .....	SOFAR 20000TL-G2, SOFAR 25000TL-G2, SOFAR 33000TL-G2
Ratings .....	<p>SOFAR 20000TL-G2: PV input: Max.1100 Vdc, MPPT voltage range: 230-960 Vdc, MPPT full power voltage range: 480-850 Vdc, max 24/24 A, Isc PV: 30/30 A Output: 400V, 3N~, 50 Hz, 20000 VA, max 3x32 A</p> <p>SOFAR 25000TL-G2: PV input: Max.1100 Vdc, MPPT voltage range: 230-960 Vdc, MPPT full power voltage range: 460-850 Vdc, max 28/28 A, Isc PV: 35/35 A Output: 400V, 3N~, 50 Hz, 25000 VA, max 3x40 A</p> <p>SOFAR 33000TL-G2: PV input: Max.1100 Vdc, MPPT voltage range: 230-960 Vdc, MPPT full power voltage range: 580-850 Vdc, max 30/30 A, Isc PV: 37.5/37.5 A Output: 400V, 3N~, 50 Hz, 33000 VA, max 3x53 A</p>

<b>Responsible Testing Laboratory (as applicable), testing procedure and testing location(s):</b>		
<input checked="" type="checkbox"/>	<b>Testing Laboratory:</b>	<b>DEKRA Testing and Certification (Shanghai) Ltd.</b>
<b>Testing location/ address .....</b>		3F, #250 Jiangchangsan Road, Building 16, Headquarter Economy Park Shibe Hi-Tech Park, Zhabei District, Shanghai 200436, China
<input checked="" type="checkbox"/>	<b>Associated Testing Laboratory:</b>	CQC-Trusted Testing Technology Co., Ltd.
<b>Testing location/ address .....</b>		No.99, Wenlan Road, Qixia, Nanjing, Jiangsu, China
<b>Tested by (name, function, signature) .....</b>		Jason Guo 
<b>Approved by (name, function, signature) ..</b>		Allan Chen 
<hr/>		
<input type="checkbox"/>	<b>Testing procedure: CTF Stage 1:</b>	
<b>Testing location/ address .....</b>		
<b>Tested by (name, function, signature) .....</b>		
<b>Approved by (name, function, signature) ..</b>		
<hr/>		
<input type="checkbox"/>	<b>Testing procedure: CTF Stage 2:</b>	
<b>Testing location/ address .....</b>		
<b>Tested by (name + signature) .....</b>		
<b>Witnessed by (name, function, signature) ..</b>		
<b>Approved by (name, function, signature) ..</b>		
<hr/>		
<input type="checkbox"/>	<b>Testing procedure: CTF Stage 3:</b>	
<input type="checkbox"/>	<b>Testing procedure: CTF Stage 4:</b>	
<b>Testing location/ address .....</b>		
<b>Tested by (name, function, signature) .....</b>		
<b>Witnessed by (name, function, signature) ..</b>		
<b>Approved by (name, function, signature) ..</b>		
<b>Supervised by (name, function, signature) :</b>		

## Copy of marking plate:

 <b>Solar Grid-tied Inverter</b>		 <b>Solar Grid-tied Inverter</b>	
Model No.	SOFAR 20000TL-G2	Model No.	SOFAR 25000TL-G2
Max.DC Input Voltage	1100V	Max.DC Input Voltage	1100V
Operating MPPT Voltage Range	230V ~ 960V	Operating MPPT Voltage Range	230V ~ 960V
Max. Input Current	24A/24A	Max. Input Current	28A/28A
Max. PV Isc	30A/30A	Max. PV Isc	35A/35A
Nominal Grid Voltage	3/N/PE, 400Vac	Nominal Grid Voltage	3/N/PE, 400Vac
Max. Output Current	3x32A	Max. Output Current	3x40A
Nominal Grid Frequency	50Hz/60Hz	Nominal Grid Frequency	50Hz/60Hz
Nominal Output Power	20000W	Nominal Output Power	25000W
Max. Output Power	22000VA	Max. Output Power	27500VA
Power Factor	>0.99(adjustable+/-0.8)	Power Factor	>0.99(adjustable+/-0.8)
Ingress Protection	IP65	Ingress Protection	IP65
Operating Temperature Range	-25~+60°C	Operating Temperature Range	-25~+60°C
Protective Class	Class I	Protective Class	Class I
Manufacturer:Shenzhen SOFARSOLAR Co., Ltd. Address:5/F,Building 4,Antongda Industrial park,NO.1 Liuxian Avenue,Xin'an Street,Bao'an District,Shenzhen City,Guangdong Province,P.R.China		Manufacturer:Shenzhen SOFARSOLAR Co., Ltd. Address:5/F,Building 4,Antongda Industrial park,NO.1 Liuxian Avenue,Xin'an Street,Bao'an District,Shenzhen City,Guangdong Province,P.R.China	
 SAA XXXXXX VDE0126-1-1,VDE-AR-N4105,G59/3,IEC61727, IEC62116,C10/11,RD1699,UTE C15-712-1,AS4777		 SAA XXXXXX VDE0126-1-1,VDE-AR-N4105,G59/3,IEC61727, IEC62116,C10/11,RD1699,UTE C15-712-1,AS4777	
       		       	

**Solar Grid-tied Inverter**

Model No.	SOFAR 33000TL-G2
Max.DC Input Voltage	1100V
Operating MPPT Voltage Range	230V ~ 960V
Max. Input Current	30A/30A
Max. PV Isc	37.5A/37.5A
Nominal Grid Voltage	3/N/PE, 400Vac
Max. Output Current	3x53A
Nominal Grid Frequency	50Hz/60Hz
Nominal Output Power	33000W
Max. Output Power	36300VA
Power Factor	>0.99(adjustable+/-0.8)
Ingress Protection	IP65
Operating Temperature Range	-25~+60°C
Protective Class	Class I

Manufacturer:Shenzhen SOFARSOLAR Co., Ltd.  
 Address:5/F,Building 4,Antongda Industrial park,NO.1 Liuxian Avenue,Xin'an Street,Bao'an District,Shenzhen City,Guangdong Province,P.R.China

 SAA XXXXXX  
 VDE0126-1-1,VDE-AR-N4105,G59/3,IEC61727,  
 IEC62116,C10/11,RD1699,UTE C15-712-1,AS4777



<b>Test item particulars</b> .....	: Grid-connected PV Inverter
Class of equipment .....	: Class I
Connection to the mains.....	: Permanent connection
IP protection class.....	: IP65
<b>Possible test case verdicts:</b>	
- test case does not apply to the test object.....	: N/A
- test object does meet the requirement.....	: P (Pass)
- test object does not meet the requirement .....	: F (Fail)
- test object was not evaluated for the requirement.....	: N/E
- this clause is information for reference only .....	: Info.
<b>Testing:</b>	
Date of receipt of test item(s) .....	: 2018-09-28 (samples provided by applicant)
Dates tests performed.....	: 2018-09-28 to 2018-10-27
<b>General remarks:</b>	
The test results presented in this report relate only to the object tested.	
This report shall not be reproduced, except in full, without the written approval of the Issuing testing laboratory.	
"(See attached table)" refers to a table appended to the report.	
"(Appendix #)" refers to additional information appended to the report.	
List of test equipment must be kept on file and available for review.	
Additional test data and/or information provided in the attachments to this report.	
Throughout this report a <input type="checkbox"/> comma / <input checked="" type="checkbox"/> point is used as the decimal separator.	
<b>Name and address of factory (ies):</b>	
Shenzhen SOFAR SOLAR Co., Ltd.	
5/F, Building 4, Antongda Industrial Park, No.1 Liuxian Avenue, Xin'an Street, Bao'an District, Shenzhen , P.R. China	

**General product information:**

The three-phase Grid-connected PV Inverter converts DC voltage into AC voltage.

The unit is providing EMC filtering at the output toward mains. The unit does not provide galvanic separation from input to output (transformerless). The output is switched off redundant by the high power switching bridge and two relays. This assures that the opening of the output circuit will also operate in case of one error.

**Block Diagram**

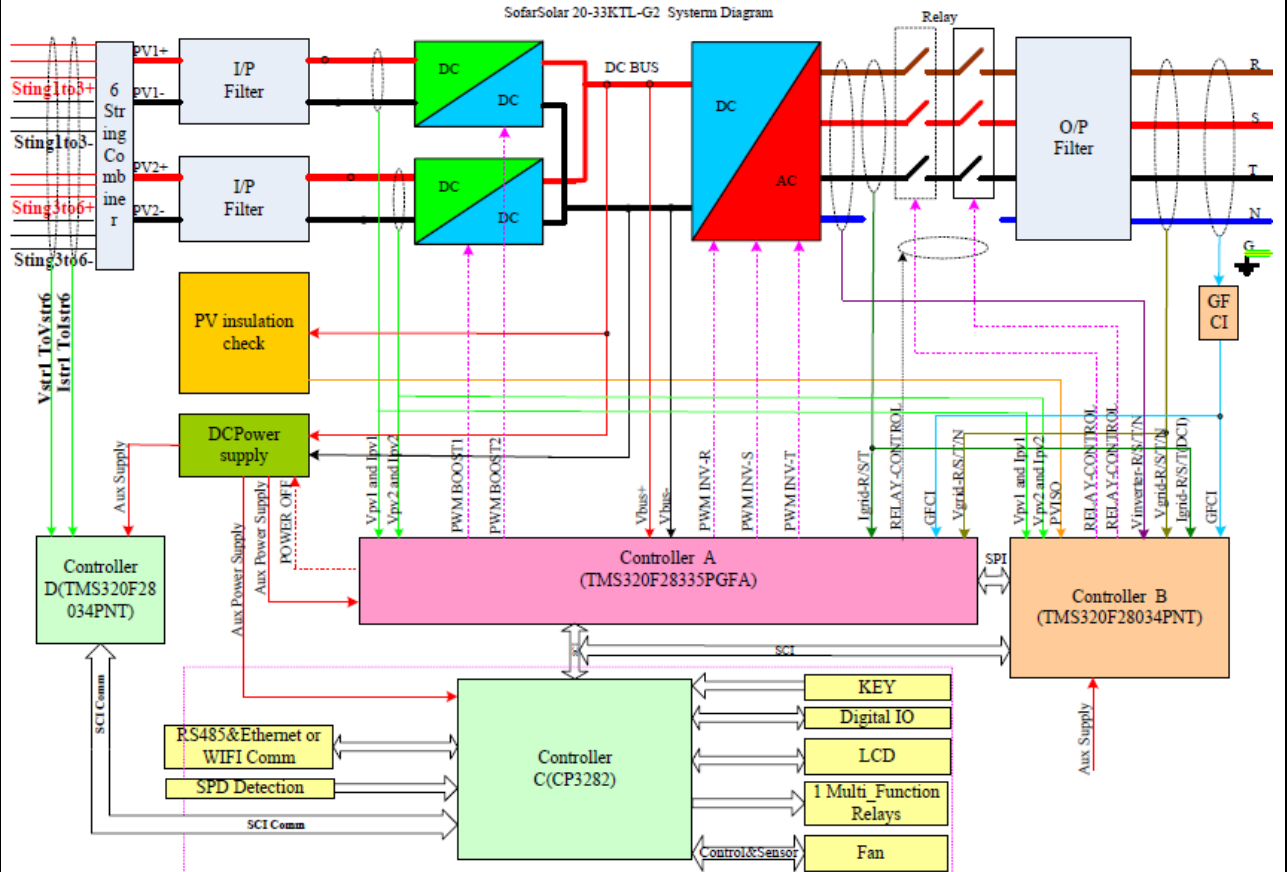

The internal control is redundant built. It consists of Main DSP and slave DSP.

The Main DSP can control the relays, measures voltage, and frequency, AC current with injected DC, insulation resistance and residual current; In addition it tests the array insulation resistance and the RCMU circuit before each start up.

The slave DSP is using for detect residual current, also can open the relays independently and communicate with Main DSP.

The unit provides two relays in series on Line conductors. When single-fault applied to one relay, alarm an error code in display panel, another redundant relay provides basic insulation maintained between the PV array and the mains. All the relays are tested before start up. Both controllers Main DSP, Slave DSP can open the relays.

The product was tested on:

Hardware version: V1.00

Software version: V1.40

EN 50530			
Clause	Requirement - Test	Result - Remark	Verdict
4	MPPT and conversion efficiencies		P
4.1	General description		P
	The MPPT efficiency describes the accuracy of an inverter to set its operating conditions to match the maximum power point on the characteristic curve of a PV generator. The MPPT efficiency is divided into the static and dynamic conditions.		P
	As with inverters with poor MPPT performance, the resulting DC input voltage is different from MPP voltage and conversion efficiency depends on DC input voltage, measurements of static MPPT efficiency and static power conversion efficiency according to 4.3 shall be performed simultaneously (detailed explanation in the informative Annex F).		P
	<p>a) Static MPPT efficiency</p> <p>The static MPPT efficiency is determined by means of measurement as follows:</p> $\eta_{MPPT_{stat}} = \frac{1}{P_{MPP,PVS} \cdot T_M} \sum_i U_{DC,i} \cdot I_{DC,i} \cdot \Delta T$ <p>The static MPPT efficiency describes the accuracy of an inverter to regulate on the maximum power point on a given static characteristic curve of a PV generator.</p>		P
	<p>b) Dynamic MPPT efficiency</p> <p>Variations of the irradiation intensity and the resulting transition of the inverter to the new operation point are not considered with the static MPPT efficiency. For the evaluation of this transient characteristic the dynamic MPPT efficiency is specified. The dynamic MPPT efficiency is defined as:</p> $\eta_{MPPT_{dyn}} = \frac{1}{\sum_j P_{MPP,PVS,j} \cdot \Delta T_j} \sum_i U_{DC,i} \cdot I_{DC,i} \cdot \Delta T_i$		P
4.2	Test set-up		P
	<p>The generic test set-up for single phase grid connected inverters is depicted in Figure 1. The diagram can also be considered as a single phase representation of a test-circuit for multi-phase inverters.</p>		P
	The DC source connected to the PV input of the inverter shall be a PV simulator in accordance to the specifications in Clause A.1.		P

EN 50530			
Clause	Requirement - Test	Result - Remark	Verdict
	The AC supply of the inverter must be in accordance to the specifications in Clause A.2.		P
	For the conversion efficiency, the DC and AC voltages shall be measured as close as possible to the inverter terminals. For MPPT efficiency, the DC voltage shall be measured as close as possible to the PV simulator. For combined conversion and MPPT efficiency measurements, two voltage measurements will be required at the output of the PVS and the DC input of the EUT, in order to avoid measurement errors resulting from the voltage drop between the PVS and the EUT.		P
4.3	Conversion and static MPPT efficiency		P
4.3.1	Test conditions		P
	The measurement of the conversion and static MPPT efficiency shall be performed simultaneously with test specifications as defined in Table 1.		P
	For test devices with several independent input terminals, the measurements must be performed for all input configurations as intended by the manufacturer. Unless otherwise provided by the manufacturer, the total power must be split equally on the individual input terminals.		P
	The measurement shall be performed at nominal grid voltage $U_{AC,r}$ in order to avoid any impact of the grid voltage level on the measurement results. Deviations must be documented in the measurement report.		P
	The measurement should be performed at an ambient temperature of $25\text{ °C} \pm 5\text{ °C}$ . Other ambient temperatures can be mutually agreed. The actual ambient temperature shall be specified in the test report.		P
4.3.2	Measurement procedure		P
	For each of the above specified test conditions a corresponding I/U characteristic has to be defined which must be emulated by means of the PV simulator.		P
	After commissioning the device under test the stabilization of the MPP tracking must be awaited firstly.		P
	The measuring time for each test condition as specified in Table 1 amounts to 10 min. For the first power level of each MPP voltage setting, the stabilisation of the MPPT-tracker has to be awaited. If a stabilisation cannot be observed a stabilisation time of at least 5 min is defined.		P
	After a change of the power level a general stabilisation period of 2 min should be used. Data recorded during the stabilisation periods are not to be considered for the calculation of the static MPPT and conversion efficiency.		P

EN 50530			
Clause	Requirement - Test	Result - Remark	Verdict
	<p>After the stabilisation of the MPP tracking the following parameters have to be logged:</p> <ul style="list-style-type: none"> <li>– <math>P_{MPP,PVS}</math>;</li> <li>– <math>P_{DC}</math>;</li> <li>– <math>U_{MPP,PVS}</math>;</li> <li>– <math>I_{MPP,PVS}</math>;</li> <li>– <math>I_{DC}</math>;</li> <li>– <math>P_{AC}</math>.</li> </ul>		P
4.3.3	Evaluation – Calculation of conversion and static MPPT efficiency		P
	For each measured power level according to Table 1, the conversion $\eta_{conv}$ and static MPPT efficiency $\eta_{MPPT}$ shall be calculated as energetic averages according to the definitions 3.4.2 and 3.4.1. The results shall be documented in the measuring report for each test condition according to Table 1.	See attached table.	P
	For each MPP voltage and each simulated I/U characteristic respectively the following particulars are to be calculated and documented in the measuring report:	See attached table.	P
	– the weighted European MPPT efficiency according to Annex D.1	See attached table.	P
	– as well as the weighted CEC MPPT efficiency (California Energy Commission) according to Annex D.2.	See attached table.	P
	Furthermore, modifications of the internal setting of the device under test, conspicuous behaviour during the measurement as well as variations from the defined procedure are to be documented.		P
4.4	Dynamic MPPT efficiency		P
4.4.1	Dynamic MPPT efficiency		P
	The measurement of the dynamic MPPT efficiency has to be performed according to the test conditions as outlined in the tables in Annex B.	See attached Table B.1 to Table B.3.	P
	The dynamics of the test sequences are generated by changes in solar irradiance. Measurements shall be performed with c-Si PV model as a basis and can additionally be made with TF model (see Table C.1). The chosen model (PV technology) shall be documented in the report.		P
	Dynamic MPPT efficiency test must be performed at rated DC voltage. For test devices with several independent input terminals, the measurements must be performed for all input configurations as intended by the manufacturer. Unless otherwise provided by the manufacturer, the total power must be split equally on the individual input terminals.		P



EN 50530			
Clause	Requirement - Test	Result - Remark	Verdict
	The measurement should be performed at an ambient temperature of 25 °C ± 5 °C. Other ambient temperatures can be mutually agreed. The actual ambient temperature shall be specified in the test report.		P
4.4.2	Measurement procedure		P
	For each of the test conditions specified in Annex B a corresponding I/V characteristic has to be defined which must be emulated by means of the PV simulator. A radiation intensity of 1 000 W/m <sup>2</sup> is related to the rated DC power P <sub>DC, r</sub> of the device under test. Previous to each test sequence a waiting period (initial set-up time) must be inserted in order to await the stabilization of the device under test. Values measured during this initial set-up time are not considered for calculation of the dynamic MPPT efficiency according to 4.4.3.		P
	For the evaluation and the determination of the dynamic MPPT efficiency the following parameters are to be recorded during the measurement: <ul style="list-style-type: none"> <li>– P<sub>MPPPVs</sub> MPP power provided by the PV simulator;</li> <li>– P<sub>DC</sub> measured input power of the device under test;</li> <li>– U<sub>MPPPVs</sub> MPP voltage provided by the PV simulator;</li> <li>– U<sub>DC</sub> measured input voltage of the device under test;</li> <li>– I<sub>MPPPVs</sub> MPP current provided by the PV simulator;</li> <li>– I<sub>DC</sub> measured input current of the device under test.</li> </ul>		P
4.4.3	Evaluation – Calculation of the dynamic MPPT efficiency		P
	The overall dynamic MPPT efficiency is the mean value of the single dynamic MPPT efficiencies of the test sequences according to tables B.1 and B.2. It is calculated by: $\eta_{MPPTdyn,t} = \frac{1}{N} \sum_{i=1}^N a_i \cdot \eta_{MPPTdyn,i}$ <ul style="list-style-type: none"> <li>– <math>\eta_{MPPTdyn,t}</math> averaged dynamic MPPT efficiency</li> <li>– <math>\eta_{MPPTdyn,i}</math> dynamic MPPT efficiency for each test sequence</li> <li>– N number of test sequences</li> <li>– a<sub>i</sub> weighting factor</li> </ul>		P
	For each test sequence according to Annex B the dynamic MPPT efficiency $\eta_{MPPT,dyn}$ is to be calculated based on the recorded data according the definition. The results are to be documented in the measuring report.	See attached table.	P
	For each test sequence the calculated MPPT efficiency is to be documented tabularly in the measuring report.	See attached table.	P

EN 50530			
Clause	Requirement - Test	Result - Remark	Verdict
	Furthermore, modifications of the internal setting of the device under test, conspicuous behaviour during the measurement as well as variations from the defined procedure are to be documented.		P
5	Calculation of the overall efficiency		P
	The DC power is converted to the AC power $P_{AC}$ by means of the conversion efficiency $\eta_{conv}$ . The actual DC power $P_{DC}$ of the device under test is the product from the static MPPT efficiency $\eta_{MPPTstat}$ and the MPP power provided by the PV simulator $P_{MPP, PVS}$ : $P_{AC} = \eta_{conv} \cdot P_{DC} = \eta_{conv} \cdot \eta_{MPPTstat} \cdot P_{MPP, PVS} = \eta_t \cdot P_{MPP, PVS}$	See attached table.	P
	The overall efficiency $\eta_t$ can also be considered as: $\eta_t = \eta_{conv} \cdot \eta_{MPPTstat} = \frac{P_{AC}}{P_{MPP, PVS}} \dots\dots\dots \text{Formula (8)}$	See attached table.	P
	Formula (8) is to be applied for each power and voltage level of Table 1. By the application of weighting factors of EUR and CEC according to D.1 and D.2, the efficiencies can summarised for each voltage level ( $U_{MPPmax}$ , $U_{DC,r}$ , $U_{MPPmin}$ ). As a result, the weighted overall efficiencies $\eta_{t,EUR}$ and $\eta_{t,CEC}$ are obtained.	See attached table.	P

4.3	TABLE: Conversion and static MPPT efficiency								P
Table 1 – Test specifications for the static MPPT efficiency									
Model	SOFAR 20000TL-G2								
MPP voltage of the simulated I/V characteristic	Simulated I/V characteristic	MPP power of the simulated I/V characteristic normalized to rated DC power, $P_{MPP,PVS} / P_{DC,r}$							
		5%	10%	20%	25%	30%	50%	75%	100%
		Static MPPT Efficiency (%)							
$U_{MPPmax}$ (850Vdc)	c-Si	97.05	99.73	95.37	99.97	99.91	99.83	99.70	98.06
$U_{DC,r}$ (620Vdc)	c-Si	99.39	99.96	99.94	99.96	99.83	99.80	99.14	98.90
$U_{MPPmin}$ (480Vdc)	c-Si	99.88	99.13	99.00	99.27	99.81	99.89	99.81	99.78
$U_{MPPmax}$ (850Vdc)	TF <sup>b)</sup>	98.96	97.62	99.92	99.63	99.93	99.83	99.75	99.43
$U_{DC,r}$ (620Vdc)	TF <sup>b)</sup>	99.96	99.69	98.45	99.07	97.43	99.81	99.73	98.73
$U_{MPPmin}$ (480Vdc)	TF <sup>b)</sup>	98.74	99.55	99.17	99.29	99.91	99.88	99.90	99.52
MPP voltage of the simulated I/V characteristic	Simulated I/V characteristic	Calculated of Static European MPPT efficiency (%)				Calculated of Static CEC MPPT efficiency (%)			
$U_{MPPmax}$ (850Vdc)	c-Si	98.81				99.46			
$U_{DC,r}$ (620Vdc)	c-Si	99.64				99.42			
$U_{MPPmin}$ (480Vdc)	c-Si	99.70				99.76			
$U_{MPPmax}$ (850Vdc)	TF	99.61				99.70			
$U_{DC,r}$ (620Vdc)	TF	99.18				99.36			
$U_{MPPmin}$ (480Vdc)	TF	99.66				99.83			
Note:									
The MPP voltages at the different test conditions ( $U_{MPPmax}$ , $U_{DC,r}$ , $U_{MPPmin}$ ) shall be kept constant during the test for each power level.									
The $U_{MPPmax}$ , $U_{DC,r}$ and $U_{MPPmin}$ was MPPT full power voltage declare by manufacturer.									

4.3	TABLE: Conversion and static MPPT efficiency								P
Table 1 – Test specifications for the static MPPT efficiency									
Model	SOFAR 25000TL-G2								
MPP voltage of the simulated I/V characteristic	Simulated I/V characteristic	MPP power of the simulated I/V characteristic normalized to rated DC power, $P_{MPP,PVS} / P_{DC,r}$							
		5%	10%	20%	25%	30%	50%	75%	100%
		Static MPPT Efficiency (%)							
$U_{MPPmax}$ (850Vdc)	c-Si	96.39	99.94	99.92	98.13	99.52	99.50	99.44	98.19
$U_{DC,r}$ (620Vdc)	c-Si	99.46	99.66	99.71	99.81	99.90	99.78	99.86	99.83
$U_{MPPmin}$ (460Vdc)	c-Si	99.33	99.83	99.93	99.83	99.82	99.86	99.95	99.95
$U_{MPPmax}$ (850Vdc)	TF	99.16	99.28	99.96	99.90	99.97	99.91	99.89	98.64
$U_{DC,r}$ (620Vdc)	TF	99.44	99.67	99.83	99.81	99.84	99.74	99.89	99.83
$U_{MPPmin}$ (460Vdc)	TF	99.87	99.84	99.95	99.98	99.73	99.85	99.87	99.86

MPP voltage of the simulated I/V characteristic	Simulated I/V characteristic	Calculated of Static European MPPT efficiency (%)	Calculated of Static CEC MPPT efficiency (%)
$U_{MPPmax}$ (850Vdc)	c-Si	99.23	99.44
$U_{DC,r}$ (620Vdc)	c-Si	99.78	99.83
$U_{MPPmin}$ (460Vdc)	c-Si	99.87	99.91
$U_{MPPmax}$ (850Vdc)	TF	99.61	99.82
$U_{DC,r}$ (620Vdc)	TF	99.77	99.84
$U_{MPPmin}$ (460Vdc)	TF	99.85	99.85

Note:  
 The MPP voltages at the different test conditions ( $U_{MPPmax}$ ,  $U_{DC,r}$ ,  $U_{MPPmin}$ ) shall be kept constant during the test for each power level.  
 The  $U_{MPPmax}$ ,  $U_{DC,r}$  and  $U_{MPPmin}$  was MPPT full power voltage declare by manufacturer.

4.3	TABLE: Conversion and static MPPT efficiency								P
<b>Table 1 – Test specifications for the static MPPT efficiency</b>									
Model	SOFAR 33000TL-G2								
MPP voltage of the simulated I/V characteristic	Simulated I/V characteristic	MPP power of the simulated I/V characteristic normalized to rated DC power, $P_{MPP,PVS} / P_{DC,r}$							
		5%	10%	20%	25%	30%	50%	75%	100%
		Static MPPT Efficiency (%)							
$U_{MPPmax}$ (850Vdc)	c-Si	98.10	99.01	99.96	99.97	99.97	99.95	99.84	99.22
$U_{DC,r}$ (620Vdc)	c-Si	99.89	99.88	99.87	99.88	99.92	99.99	99.99	99.76
$U_{MPPmin}$ (580Vdc)	c-Si	97.96	99.31	99.88	99.94	99.89	99.88	99.87	99.80
$U_{MPPmax}$ (850Vdc)	TF	99.85	99.89	99.95	99.97	99.86	99.90	99.36	99.60
$U_{DC,r}$ (620Vdc)	TF	99.69	99.89	99.71	99.65	99.70	99.47	99.90	99.71
$U_{MPPmin}$ (580Vdc)	TF	99.57	98.38	99.80	99.90	99.87	99.83	99.87	99.82
MPP voltage of the simulated I/V characteristic	Simulated I/V characteristic	Calculated of Static European MPPT efficiency (%)				Calculated of Static CEC MPPT efficiency (%)			
$U_{MPPmax}$ (850Vdc)	c-Si	99.70				99.82			
$U_{DC,r}$ (620Vdc)	c-Si	99.91				99.96			
$U_{MPPmin}$ (580Vdc)	c-Si	99.77				99.85			
$U_{MPPmax}$ (850Vdc)	TF	99.84				99.60			
$U_{DC,r}$ (620Vdc)	TF	99.60				99.77			
$U_{MPPmin}$ (580Vdc)	TF	99.73				99.80			

Note:  
 The MPP voltages at the different test conditions ( $U_{MPPmax}$ ,  $U_{DC,r}$ ,  $U_{MPPmin}$ ) shall be kept constant during the test for each power level.  
 The  $U_{MPPmax}$ ,  $U_{DC,r}$  and  $U_{MPPmin}$  was MPPT full power voltage declare by manufacturer.

D.1 European efficiency

$$\eta_{MPPTstat, EUR} = a_{EU_1} \cdot \eta_{MPP_1} + a_{EU_2} \cdot \eta_{MPP_2} + a_{EU_3} \cdot \eta_{MPP_3} + a_{EU_4} \cdot \eta_{MPP_4} + a_{EU_5} \cdot \eta_{MPP_5} + a_{EU_6} \cdot \eta_{MPP_6}$$

Weighting Factor	$a_{EU_1}$	$a_{EU_2}$	$a_{EU_3}$	$a_{EU_4}$	$a_{EU_5}$	$a_{EU_6}$
	0.03	0.06	0.13	0.1	0.48	0.2
Partial MPP power $P_{MPP,PVs}/P_{DC,r}$	MPP_1	MPP_2	MPP_3	MPP_4	MPP_5	MPP_6
	0.05	0.1	0.2	0.3	0.5	1

## D.2 CEC efficiency

$$\eta_{MPPTstat,CEC} = a_{CEC_1} \cdot \eta_{MPP_1} + a_{CEC_2} \cdot \eta_{MPP_2} + a_{CEC_3} \cdot \eta_{MPP_3} + a_{CEC_4} \cdot \eta_{MPP_4} + a_{CEC_5} \cdot \eta_{MPP_5} + a_{CEC_6} \cdot \eta_{MPP_6}$$

4.3	TABLE: Conversion and static MPPT efficiency								P
Table 2 –Test specification for the conversion efficiency									
Model	SOFAR 20000TL-G2								
MPP voltage of the simulated I/V characteristic	Simulated I/V characteristic	MPP power of the simulated I/V characteristic normalized to rated DC power, $P_{MPP,PVS} / P_{DC,r}$							
		5%	10%	20%	25%	30%	50%	75%	100%
		Conversion Efficiency (%)							
$U_{MPPmax}$ (850Vdc)	c-Si	91.26	94.05	96.15	96.50	96.73	97.03	97.02	97.27
$U_{DC,r}$ (620Vdc)	c-Si	93.90	96.14	97.16	97.34	97.45	97.55	97.48	97.33
$U_{MPPmin}$ (480Vdc)	c-Si	93.50	95.74	96.80	97.03	97.11	97.32	97.26	97.08
$U_{MPPmax}$ (850Vdc)	TF	90.94	94.55	96.21	96.61	96.76	97.04	97.04	96.94
$U_{DC,r}$ (620Vdc)	TF	93.90	96.18	97.17	97.30	97.43	97.54	97.49	97.36
$U_{MPPmin}$ (480Vdc)	TF	93.39	95.68	96.81	97.05	97.08	97.27	97.20	97.02
MPP voltage of the simulated I/V characteristic	Simulated I/V characteristic	Calculated of European Conversion efficiency (%)				Calculated of CEC Conversion efficiency (%)			
$U_{MPPmax}$ (850Vdc)	c-Si	96.58				96.84			
$U_{DC,r}$ (620Vdc)	c-Si	97.25				97.41			
$U_{MPPmin}$ (480Vdc)	c-Si	96.97				97.16			
$U_{MPPmax}$ (850Vdc)	TF	96.55				96.86			
$U_{DC,r}$ (620Vdc)	TF	97.25				97.42			
$U_{MPPmin}$ (480Vdc)	TF	96.93				97.11			
Note:									
The MPP voltages at the different test conditions ( $U_{MPPmax}$ , $U_{DC,r}$ , $U_{MPPmin}$ ) shall be kept constant during the test for each power level.									
The $U_{MPPmax}$ , $U_{DC,r}$ and $U_{MPPmin}$ was MPPT full power voltage declare by manufacturer.									

4.3	TABLE: Conversion and static MPPT efficiency								P
Table 2 –Test specification for the conversion efficiency									
Model	SOFAR 25000TL-G2								
MPP voltage of the simulated I/V characteristic	Simulated I/V characteristic	MPP power of the simulated I/V characteristic normalized to rated DC power, $P_{MPP,PVS} / P_{DC,r}$							
		5%	10%	20%	25%	30%	50%	75%	100%
		Conversion Efficiency (%)							
$U_{MPPmax}$ (850Vdc)	c-Si	92.43	94.99	96.59	96.80	96.98	97.14	97.11	97.02
$U_{DC,r}$ (620Vdc)	c-Si	95.34	97.03	97.78	97.94	98.01	98.01	97.94	97.73
$U_{MPPmin}$ (460Vdc)	c-Si	94.16	96.03	96.97	97.16	97.25	97.37	97.22	96.96
$U_{MPPmax}$ (850Vdc)	TF	92.53	95.14	96.59	96.87	97.03	97.23	97.19	96.97
$U_{DC,r}$ (620Vdc)	TF	95.51	96.47	97.85	97.99	97.99	98.06	98.01	97.87
$U_{MPPmin}$ (460Vdc)	TF	94.20	96.03	96.94	97.14	97.24	97.36	97.21	96.94

MPP voltage of the simulated I/V characteristic	Simulated I/V characteristic	Calculated of European Conversion efficiency (%)	Calculated of CEC Conversion efficiency (%)
$U_{MPPmax}$ (850Vdc)	c-Si	96.76	96.99
$U_{DC,r}$ (620Vdc)	c-Si	97.79	97.91
$U_{MPPmin}$ (460Vdc)	c-Si	97.05	97.18
$U_{MPPmax}$ (850Vdc)	TF	96.81	97.06
$U_{DC,r}$ (620Vdc)	TF	97.82	97.94
$U_{MPPmin}$ (460Vdc)	TF	97.03	97.17

Note:  
The MPP voltages at the different test conditions ( $U_{MPPmax}$ ,  $U_{DC,r}$ ,  $U_{MPPmin}$ ) shall be kept constant during the test for each power level.  
The  $U_{MPPmax}$ ,  $U_{DC,r}$  and  $U_{MPPmin}$  was MPPT full power voltage declare by manufacturer.

4.3	TABLE: Conversion and static MPPT efficiency								P
<b>Table 2 –Test specification for the conversion efficiency</b>									
Model	SOFAR 33000TL-G2								
MPP voltage of the simulated I/V characteristic	Simulated I/V characteristic	MPP power of the simulated I/V characteristic normalized to rated DC power, $P_{MPP,PVS} / P_{DC,r}$							
		5%	10%	20%	25%	30%	50%	75%	100%
		Conversion Efficiency (%)							
$U_{MPPmax}$ (850Vdc)	c-Si	94.73	96.52	97.40	97.52	97.58	97.60	97.47	97.28
$U_{DC,r}$ (620Vdc)	c-Si	96.31	97.57	98.01	98.06	98.10	98.06	97.89	97.68
$U_{MPPmin}$ (580Vdc)	c-Si	95.40	97.07	97.66	97.70	97.74	97.69	97.46	97.22
$U_{MPPmax}$ (850Vdc)	TF	94.55	96.55	97.47	97.59	97.64	97.63	97.47	97.28
$U_{DC,r}$ (620Vdc)	TF	95.93	97.21	97.74	97.80	97.68	97.55	97.63	97.57
$U_{MPPmin}$ (580Vdc)	TF	95.68	97.13	97.61	97.69	97.75	97.70	97.43	97.29
MPP voltage of the simulated I/V characteristic	Simulated I/V characteristic	Calculated of European Conversion efficiency (%)				Calculated of CEC Conversion efficiency (%)			
$U_{MPPmax}$ (850Vdc)	c-Si	97.36				97.46			
$U_{DC,r}$ (620Vdc)	c-Si	97.90				97.93			
$U_{MPPmin}$ (580Vdc)	c-Si	97.49				97.52			
$U_{MPPmax}$ (850Vdc)	TF	97.38				97.48			
$U_{DC,r}$ (620Vdc)	TF	97.52				97.60			
$U_{MPPmin}$ (580Vdc)	TF	97.52				97.52			

Note:  
The MPP voltages at the different test conditions ( $U_{MPPmax}$ ,  $U_{DC,r}$ ,  $U_{MPPmin}$ ) shall be kept constant during the test for each power level.  
The  $U_{MPPmax}$ ,  $U_{DC,r}$  and  $U_{MPPmin}$  was MPPT full power voltage declare by manufacturer.

D.1 European efficiency

$$\eta_{MPPTstat, EUR} = a_{EU_1} \cdot \eta_{MPP_1} + a_{EU_2} \cdot \eta_{MPP_2} + a_{EU_3} \cdot \eta_{MPP_3} + a_{EU_4} \cdot \eta_{MPP_4} + a_{EU_5} \cdot \eta_{MPP_5} + a_{EU_6} \cdot \eta_{MPP_6}$$

Weighting Factor	a <sub>EU_1</sub>	a <sub>EU_2</sub>	a <sub>EU_3</sub>	a <sub>EU_4</sub>	a <sub>EU_5</sub>	a <sub>EU_6</sub>
	0.03	0.06	0.13	0.1	0.48	0.2
Partial MPP power $P_{MPP,PVs}/P_{DC,r}$	MPP_1	MPP_2	MPP_3	MPP_4	MPP_5	MPP_6
	0.05	0.1	0.2	0.3	0.5	1

## D.2 CEC efficiency

$$\eta_{MPPTstat,CEC} = a_{CEC_1} \cdot \eta_{MPP_1} + a_{CEC_2} \cdot \eta_{MPP_2} + a_{CEC_3} \cdot \eta_{MPP_3} + a_{CEC_4} \cdot \eta_{MPP_4} + a_{CEC_5} \cdot \eta_{MPP_5} + a_{CEC_6} \cdot \eta_{MPP_6}$$

Weighting Factor	a <sub>CEC_1</sub>	a <sub>CEC_2</sub>	a <sub>CEC_3</sub>	a <sub>CEC_4</sub>	a <sub>CEC_5</sub>	a <sub>CEC_6</sub>
	0.04	0.05	0.12	0.21	0.53	0.05
Partial MPP power $P_{MPP,PVs}/P_{DC,r}$	MPP_1	MPP_2	MPP_3	MPP_4	MPP_5	MPP_6
	0.1	0.2	0.3	0.5	0.75	1

4.4	TABLE: Dynamic MPPT Efficiency						P
Table B.1 – Dynamic MPPT-Test 10 % → 50 % $G_{STC}$ (valid for the evaluation of $\eta_{MPPTdyn}$ )							
Model	SOFAR 20000TL-G2						
Repetition Number	Slope (W/m <sup>2</sup> /s)	Ramp UP (s)	Dwell time (s)	Ramp DN (s)	Dwell time (s)	Duration (s)	Efficiency (%)
2	0,5	800	10	800	10	3540	99.59
2	1	400	10	400	10	1940	98.87
3	2	200	10	200	10	1560	98.99
4	3	133	10	133	10	1444	99.00
6	5	80	10	80	10	1380	98.81
8	7	57	10	57	10	1372	98.71
10	10	40	10	40	10	1300	97.41
10	14	29	10	29	10	1080	98.11
10	20	20	10	20	10	900	98.20
10	30	13	10	13	10	760	98.20
10	50	8	10	8	10	660	98.06
-	-	-	-	-	Total	15 936 s	-
-	-	-	-	-	-	04:25:36 h	-
Note: Ramp and dwell times are given as rounded values.							

4.4	TABLE: Dynamic MPPT Efficiency						P
Table B.1 – Dynamic MPPT-Test 10 % → 50 % $G_{STC}$ (valid for the evaluation of $\eta_{MPPTdyn}$ )							
Model	SOFAR 25000TL-G2						
Repetition	Slope	Ramp UP	Dwell time	Ramp DN	Dwell time	Duration	Efficiency



Number	(W/m <sup>2</sup> /s)	(s)	(s)	(s)	(s)	(s)	(%)
2	0,5	800	10	800	10	3540	99.45
2	1	400	10	400	10	1940	98.65
3	2	200	10	200	10	1560	99.07
4	3	133	10	133	10	1444	98.39
6	5	80	10	80	10	1380	98.05
8	7	57	10	57	10	1372	99.22
10	10	40	10	40	10	1300	98.21
10	14	29	10	29	10	1080	98.16
10	20	20	10	20	10	900	98.33
10	30	13	10	13	10	760	97.44
10	50	8	10	8	10	660	98.27
-	-	-	-	-	Total	15 936 s	-
-	-	-	-	-	-	04:25:36 h	-

Note:  
Ramp and dwell times are given as rounded values.

4.4		TABLE: Dynamic MPPT Efficiency					P	
<b>Table B.1 – Dynamic MPPT-Test 10 % → 50 % <math>G_{STC}</math> (valid for the evaluation of <math>\eta_{MPPT_{dyn}}</math>)</b>								
Model		SOFAR 33000TL-G2						
Repetition Number	Slope (W/m <sup>2</sup> /s)	Ramp UP (s)	Dwell time (s)	Ramp DN (s)	Dwell time (s)	Duration (s)	Efficiency (%)	
2	0,5	800	10	800	10	3540	99.59	
2	1	400	10	400	10	1940	98.80	
3	2	200	10	200	10	1560	99.15	
4	3	133	10	133	10	1444	99.49	
6	5	80	10	80	10	1380	99.18	
8	7	57	10	57	10	1372	98.98	
10	10	40	10	40	10	1300	97.27	
10	14	29	10	29	10	1080	97.09	
10	20	20	10	20	10	900	97.35	
10	30	13	10	13	10	760	97.44	
10	50	8	10	8	10	660	95.86	
-	-	-	-	-	Total	15 936 s	-	
-	-	-	-	-	-	04:25:36 h	-	

Note:  
Ramp and dwell times are given as rounded values.

4.4		TABLE: Dynamic MPPT Efficiency						P
Table B.2 – Dynamic MPPT-Test 30 % → 100 % $G_{STC}$ (valid for the evaluation of $\eta_{MPPTdyn}$ )								
Model		SOFAR 20000TL-G2						
Repetition Number	Slope (W/m <sup>2</sup> /s)	Ramp UP (s)	Dwell time (s)	Ramp DN (s)	Dwell time (s)	Duration (s)	Efficiency (%)	
10	10	70	10	70	10	1900	99.58	
10	14	50	10	50	10	1500	99.76	
10	20	35	10	35	10	1200	99.66	
10	30	23	10	23	10	960	99.66	
10	50	14	10	14	10	780	99.68	
10	100	7	10	7	10	640	99.83	
-	-	-	-	-	Total	6 980 s	-	
-	-	-	-	-	-	01:56:20 h	-	
Note: Ramp and dwell times are given as rounded values.								

4.4		TABLE: Dynamic MPPT Efficiency						P
Table B.2 – Dynamic MPPT-Test 30 % → 100 % $G_{STC}$ (valid for the evaluation of $\eta_{MPPTdyn}$ )								
Model		SOFAR 25000TL-G2						
Repetition Number	Slope (W/m <sup>2</sup> /s)	Ramp UP (s)	Dwell time (s)	Ramp DN (s)	Dwell time (s)	Duration (s)	Efficiency (%)	
10	10	70	10	70	10	1900	97.97	
10	14	50	10	50	10	1500	98.17	
10	20	35	10	35	10	1200	98.15	
10	30	23	10	23	10	960	98.11	
10	50	14	10	14	10	780	98.03	
10	100	7	10	7	10	640	97.77	
-	-	-	-	-	Total	6 980 s	-	
-	-	-	-	-	-	01:56:20 h	-	
Note: Ramp and dwell times are given as rounded values.								

4.4		TABLE: Dynamic MPPT Efficiency						P
Table B.2 – Dynamic MPPT-Test 30 % → 100 % $G_{STC}$ (valid for the evaluation of $\eta_{MPPTdyn}$ )								
Model		SOFAR 33000TL-G2						
Repetition Number	Slope (W/m <sup>2</sup> /s)	Ramp UP (s)	Dwell time (s)	Ramp DN (s)	Dwell time (s)	Duration (s)	Efficiency (%)	
10	10	70	10	70	10	1900	98.36	

10	14	50	10	50	10	1500	98.28
10	20	35	10	35	10	1200	98.66
10	30	23	10	23	10	960	98.24
10	50	14	10	14	10	780	98.52
10	100	7	10	7	10	640	98.17
-	-	-	-	-	Total	6 980 s	-
-	-	-	-	-	-	01:56:20 h	-

Note:  
Ramp and dwell times are given as rounded values.

<b>4.4</b>	<b>TABLE: Dynamic MPPT Efficiency</b>						<b>P</b>
<b>Table B.3 – Start-up and shut-down test with slow ramps</b>							
Model	SOFAR 20000TL-G2						
Repetition Number	Slope (W/m <sup>2</sup> /s)	Ramp UP (s)	Dwell time (s)	Ramp DN (s)	Dwell time (s)	Duration (s)	Efficiency (%)
1	0,1	980	30	980	30	2320	99.82
-	-	-	-	-	Total	2 320 s	-
-	-	-	-	-	-	00:38:40 h	-

Note:

<b>4.4</b>	<b>TABLE: Dynamic MPPT Efficiency</b>						<b>P</b>
<b>Table B.3 – Start-up and shut-down test with slow ramps</b>							
Model	SOFAR 25000TL-G2						
Repetition Number	Slope (W/m <sup>2</sup> /s)	Ramp UP (s)	Dwell time (s)	Ramp DN (s)	Dwell time (s)	Duration (s)	Efficiency (%)
1	0,1	980	30	980	30	2320	99.76
-	-	-	-	-	Total	2 320 s	-
-	-	-	-	-	-	00:38:40 h	-

Note:

<b>4.4</b>	<b>TABLE: Dynamic MPPT Efficiency</b>						<b>P</b>
<b>Table B.3 – Start-up and shut-down test with slow ramps</b>							
Model	SOFAR 33000TL-G2						
Repetition Number	Slope (W/m <sup>2</sup> /s)	Ramp UP (s)	Dwell time (s)	Ramp DN (s)	Dwell time (s)	Duration (s)	Efficiency (%)
1	0,1	980	30	980	30	2320	99.14
-	-	-	-	-	Total	2 320 s	-
-	-	-	-	-	-	00:38:40 h	-

Note:

5	TABLE: Overall Efficiency								P
Model	SOFAR 20000TL-G2								
MPP voltage of the simulated I/V characteristic	Simulated I/V characteristic	$\eta_r = \eta_{conv} \cdot \eta_{MPPTstat} = \frac{P_{AC}}{P_{MPP,PVS}}$							
		5%	10%	20%	25%	30%	50%	75%	100%
		Overall Efficiency (%)							
$U_{MPPmax}$ , (850Vdc)	c-Si	88.57	93.80	91.70	96.47	96.64	96.87	96.73	95.38
$U_{DC,r}$ (620Vdc)	c-Si	93.33	96.10	97.10	97.30	97.28	97.35	96.64	96.26
$U_{MPPmin}$ (480Vdc)	c-Si	93.39	94.91	95.83	96.32	96.93	97.21	97.08	96.87
$U_{MPPmax}$ , (850Vdc)	TF	89.99	92.30	96.13	96.25	96.69	96.88	96.80	96.39
$U_{DC,r}$ (620Vdc)	TF	93.86	95.88	95.66	96.40	94.93	97.35	97.23	96.12
$U_{MPPmin}$ (480Vdc)	TF	92.21	95.25	96.01	96.36	96.99	97.15	97.10	96.55
MPP voltage of the simulated I/V characteristic	Simulated I/V characteristic	Calculated of Overall European efficiency (%)				Calculated of Overall CEC efficiency (%)			
$U_{MPPmax}$ , (850Vdc)	c-Si	95.44				96.31			
$U_{DC,r}$ (620Vdc)	c-Si	96.90				96.85			
$U_{MPPmin}$ (480Vdc)	c-Si	96.68				96.93			
$U_{MPPmax}$ , (850Vdc)	TF	96.18				96.57			
$U_{DC,r}$ (620Vdc)	TF	96.45				96.79			
$U_{MPPmin}$ (480Vdc)	TF	96.61				96.94			
Note: The $U_{MPPmax}$ , $U_{DC,r}$ and $U_{MPPmin}$ was MPPT full power voltage declare by manufacturer.									

5	TABLE: Overall Efficiency								P
Model	SOFAR 25000TL-G2								
MPP voltage of the simulated I/V characteristic	Simulated I/V characteristic	$\eta_r = \eta_{conv} \cdot \eta_{MPPTstat} = \frac{P_{AC}}{P_{MPP,PVS}}$							
		5%	10%	20%	25%	30%	50%	75%	100%
		Overall Efficiency (%)							
$U_{MPPmax}$ , (850Vdc)	c-Si	89.09	94.93	96.51	94.99	96.51	96.65	96.57	95.26
$U_{DC,r}$ (620Vdc)	c-Si	94.83	96.70	97.50	97.75	97.91	97.79	97.80	97.56
$U_{MPPmin}$ (460Vdc)	c-Si	93.53	95.87	96.90	96.99	97.07	97.23	97.17	96.91
$U_{MPPmax}$ , (850Vdc)	TF	91.75	94.45	96.55	96.77	97.00	97.14	97.08	95.65
$U_{DC,r}$ (620Vdc)	TF	94.98	96.15	97.68	97.80	97.83	97.81	97.90	97.70
$U_{MPPmin}$ (460Vdc)	TF	94.08	95.88	96.89	97.12	96.98	97.21	97.08	96.80
MPP voltage of the simulated I/V	Simulated I/V characteristic	Calculated of Overall European efficiency (%)				Calculated of Overall CEC efficiency (%)			

characteristic			
$U_{MPPmax}$ , (850Vdc)	c-Si	96.01	96.45
$U_{DC,r}$ (620Vdc)	c-Si	97.57	97.74
$U_{MPPmin}$ (460Vdc)	c-Si	96.92	97.09
$U_{MPPmax}$ , (850Vdc)	TF	96.43	96.88
$U_{DC,r}$ (620Vdc)	TF	97.59	97.78
$U_{MPPmin}$ (460Vdc)	TF	96.89	97.03
<b>Note:</b> The $U_{MPPmax}$ , $U_{DC,r}$ and $U_{MPPmin}$ was MPPT full power voltage declare by manufacturer.			

5	TABLE: Overall Efficiency								P
Model	SOFAR 33000TL-G2								
MPP voltage of the simulated I/V characteristic	Simulated I/V characteristic	$\eta_r = \eta_{conv} \cdot \eta_{MPPTstat} = \frac{P_{AC}}{P_{MPP,PVS}}$							
		5%	10%	20%	25%	30%	50%	75%	100%
		Overall Efficiency (%)							
$U_{MPPmax}$ , (850Vdc)	c-Si	92.93	95.56	97.36	97.49	97.55	97.55	97.31	96.52
$U_{DC,r}$ (620Vdc)	c-Si	96.20	97.45	97.88	97.94	98.02	98.05	97.88	97.45
$U_{MPPmin}$ (580Vdc)	c-Si	93.45	96.40	97.54	97.64	97.63	97.57	97.33	97.02
$U_{MPPmax}$ , (850Vdc)	TF	94.41	96.44	97.42	97.56	97.50	97.53	96.85	96.89
$U_{DC,r}$ (620Vdc)	TF	95.63	97.10	97.46	97.46	97.39	97.03	97.53	97.29
$U_{MPPmin}$ (580Vdc)	TF	95.27	95.56	97.41	97.59	97.62	97.53	97.30	97.11
MPP voltage of the simulated I/V characteristic	Simulated I/V characteristic	Calculated of Overall European efficiency (%)				Calculated of Overall CEC efficiency (%)			
$U_{MPPmax}$ , (850Vdc)	c-Si	97.06				97.28			
$U_{DC,r}$ (620Vdc)	c-Si	97.81				97.89			
$U_{MPPmin}$ (580Vdc)	c-Si	97.27				97.37			
$U_{MPPmax}$ , (850Vdc)	TF	97.23				97.08			
$U_{DC,r}$ (620Vdc)	TF	97.14				97.38			
$U_{MPPmin}$ (580Vdc)	TF	97.25				97.31			
<b>Note:</b> The $U_{MPPmax}$ , $U_{DC,r}$ and $U_{MPPmin}$ was MPPT full power voltage declare by manufacturer.									

The DC power is converted to the AC power  $P_{AC}$  by means of the conversion efficiency  $\eta_{conv}$ . The actual DC power  $P_{DC}$  of the device under test is the product from the static MPPT efficiency  $\eta_{MPPTstat}$  and the MPP power provided by the PV simulator  $P_{MPP,PVS}$ :

$$P_{AC} = \eta_{conv} \cdot P_{DC} = \eta_{conv} \cdot \eta_{MPPTstat} \cdot P_{MPP,PVS} = \eta_r \cdot P_{MPP,PVS} \quad (7)$$

The overall efficiency  $\eta_r$  can also be considered as

$$\eta_r = \eta_{conv} \cdot \eta_{MPPTstat} = \frac{P_{AC}}{P_{MPP,PVS}} \quad (8)$$

#### D.1 European efficiency

$$\eta_{MPPTstat, EUR} = a_{EU_1} \cdot \eta_{MPP_1} + a_{EU_2} \cdot \eta_{MPP_2} + a_{EU_3} \cdot \eta_{MPP_3} + a_{EU_4} \cdot \eta_{MPP_4} \\ + a_{EU_5} \cdot \eta_{MPP_5} + a_{EU_6} \cdot \eta_{MPP_6}$$

Weighting Factor	$a_{EU_1}$	$a_{EU_2}$	$a_{EU_3}$	$a_{EU_4}$	$a_{EU_5}$	$a_{EU_6}$
	0.03	0.06	0.13	0.1	0.48	0.2
Partial MPP power $P_{MPP,PVS}/P_{DC,r}$	MPP_1	MPP_2	MPP_3	MPP_4	MPP_5	MPP_6
	0.05	0.1	0.2	0.3	0.5	1

#### D.2 CEC efficiency

$$\eta_{MPPTstat, CEC} = a_{CEC_1} \cdot \eta_{MPP_1} + a_{CEC_2} \cdot \eta_{MPP_2} + a_{CEC_3} \cdot \eta_{MPP_3} + a_{CEC_4} \cdot \eta_{MPP_4} \\ + a_{CEC_5} \cdot \eta_{MPP_5} + a_{CEC_6} \cdot \eta_{MPP_6}$$

Weighting Factor	$a_{CEC_1}$	$a_{CEC_2}$	$a_{CEC_3}$	$a_{CEC_4}$	$a_{CEC_5}$	$a_{CEC_6}$
	0.04	0.05	0.12	0.21	0.53	0.05
Partial MPP power $P_{MPP,PVS}/P_{DC,r}$	MPP_1	MPP_2	MPP_3	MPP_4	MPP_5	MPP_6
	0.1	0.2	0.3	0.5	0.75	1

**Appendix 1: Pictures**

SOFAR 20000TL-G2 Enclosure Front View

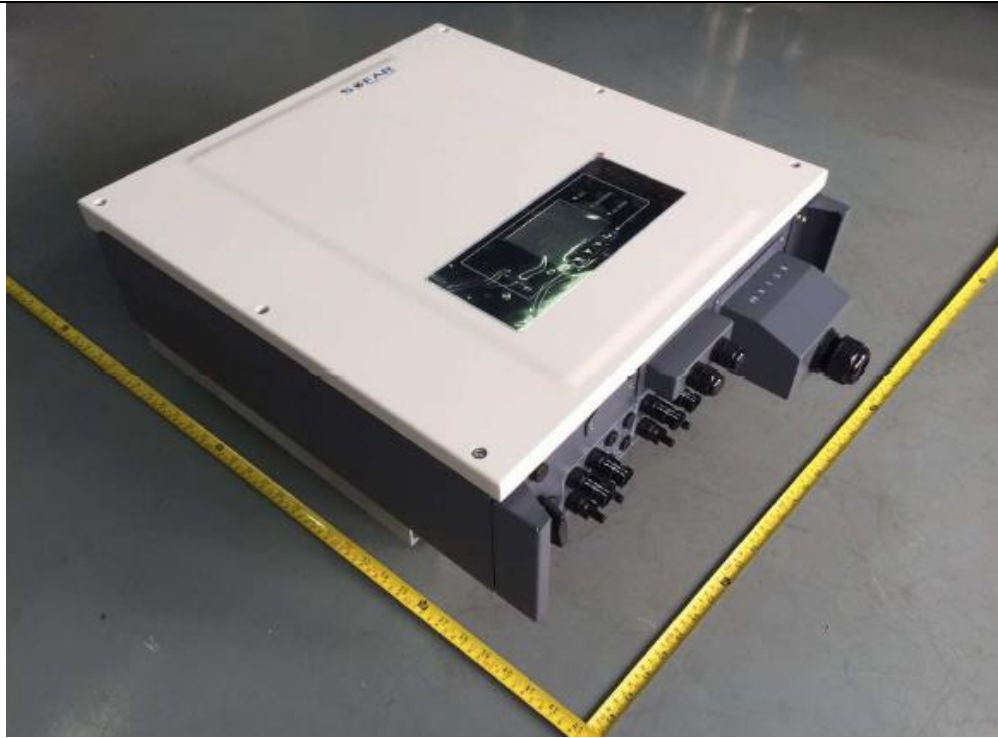

SOFAR 20000TL-G2 Enclosure Rear View

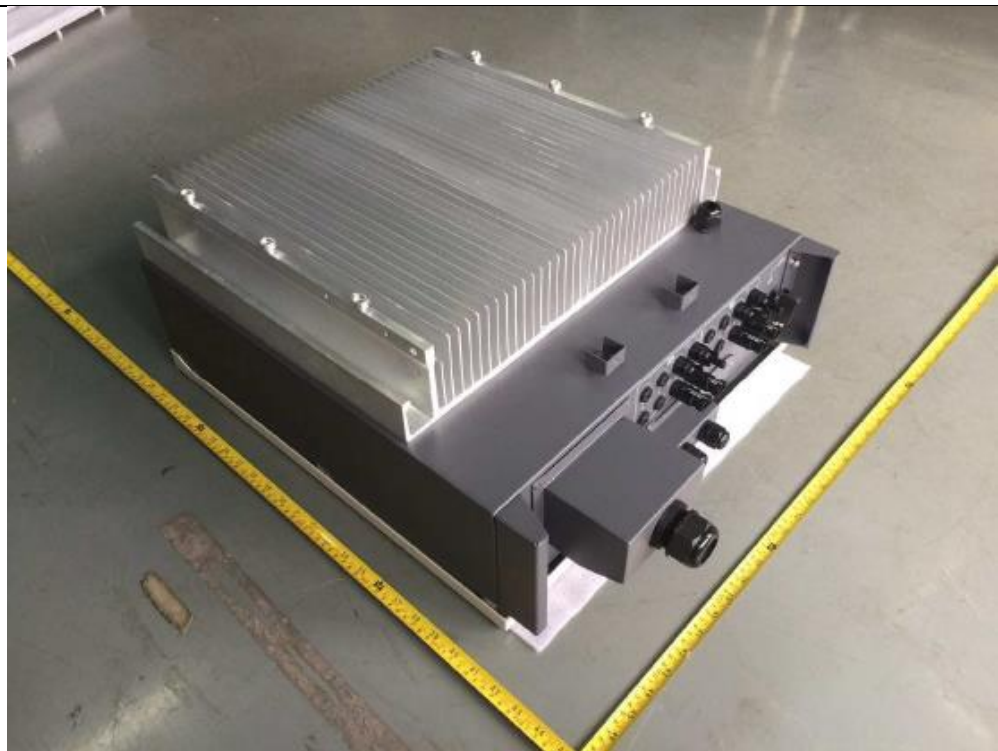

SOFAR 20000TL-G2 Enclosure Bottom View



SOFAR 20000TL-G2 Internal View





SOFAR 25000TL-G2 Enclosure Front View



SOFAR 25000TL-G2 Enclosure Rear View



SOFAR 25000TL-G2 Enclosure Bottom View



SOFAR 25000TL-G2 Internal View

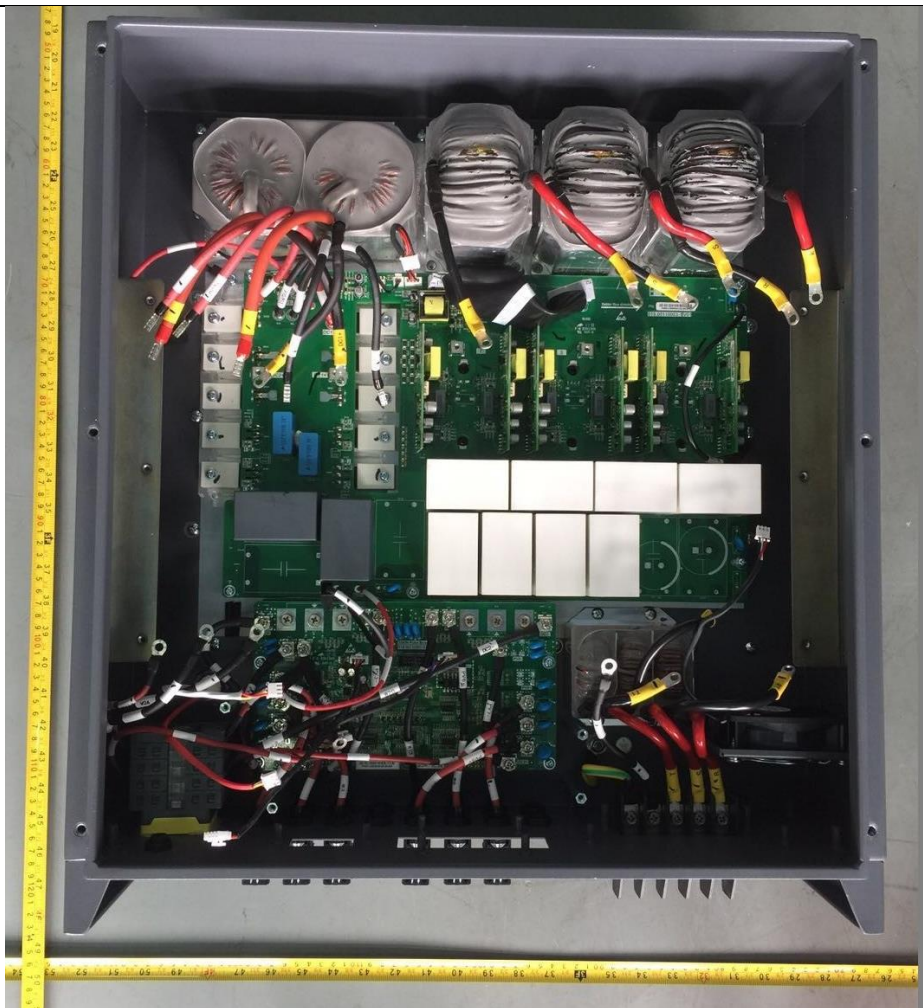

SOFAR 33000TL-G2 Enclosure Front View



SOFAR 33000TL-G2 Enclosure Rear View



SOFAR 33000TL-G2 Enclosure Bottom View



SOFAR 33000TL-G2 Internal View

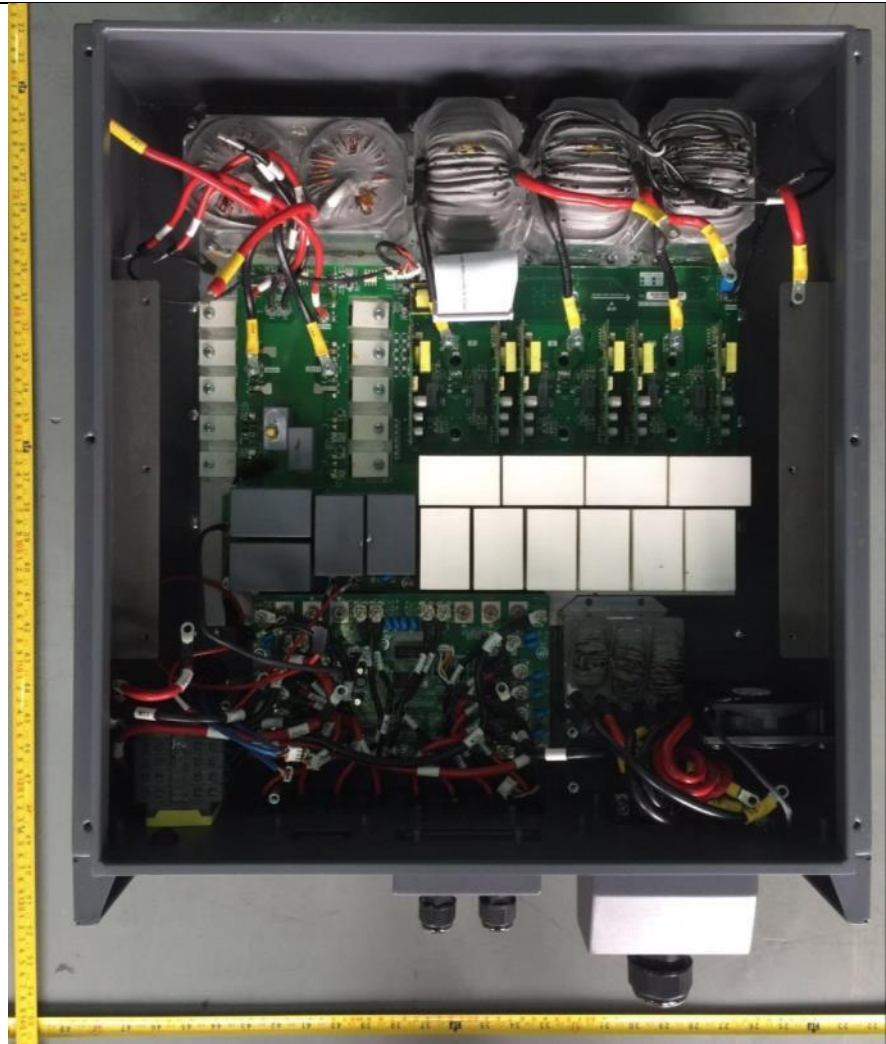

**Appendix 2: List of test equipment used:**

No.	Testing / measuring equipment	Type	Internal no.	manufacturer	Calibration due date
1	AC simulator	RS90	CTTEQ-4	AMETEK EIG	2019-03-20
2	PV simulator	TC/P/32	CTTEQ-1	Regatron AG	2019-03-20
3	PV simulator	TC/P/32	CTTEQ-2	Regatron AG	2019-03-20
4	Power analyzer	WT3000	CEETQ-5	Yokogawa	2019-01-16
5	Current sensor	CT6863	CTTEQ-90	HOIKI	2019-03-15
6	Current sensor	CT6863	CTTEQ-92	HOIKI	2019-03-15
7	Current sensor	CT6863	CTTEQ-94	HOIKI	2019-03-15
8	Current sensor	CT6863	CTTEQ-95	HOIKI	2019-03-15
9	Temperature and humidity Meter	608-H1	CTTEQ-189	Testo	2019-05-03
10	Air pressure gauge	DYM3	CTTEQ-77	Ningbo Yinzhou Jiangshan Glass Instruments factory	2019-03-06

-----END-----